

The Model 3201 Liquid Level Controller is ideal for oilfield scrubber and separator applications. Its rugged and versatile design make it the preferred choice of production operators for reliable service in a wide variety of applications. Available in caged and cageless configurations with a variety of displacer sizes, materials, and vessel connection options.

### Features:

- **Pneumatic Non-bleeding Pilots** - The Model 3201 can be fitted with either of two non-bleeding pilots: a snap pilot for on/off service or a throttle pilot for modulating service. The controller can be quickly and easily converted from snap to throttle or vice versa.
- **Field Reversible Action** - The Model 3201 design makes reversing the controller action simple. Requires no additional parts or special tools.
- **Liquid Interface Control** - The Model 3201 is well-suited for liquid-liquid interface detection.
- **Displacers** - Mallard offers a variety of displacer materials and designs to satisfy your application requirements. Standard material offerings are PVC, Acrylic, and 316 Stainless Steel.
- **NACE** - The Model 3201 is available with wetted materials that meet NACE MR-01-75 specifications for sour service.

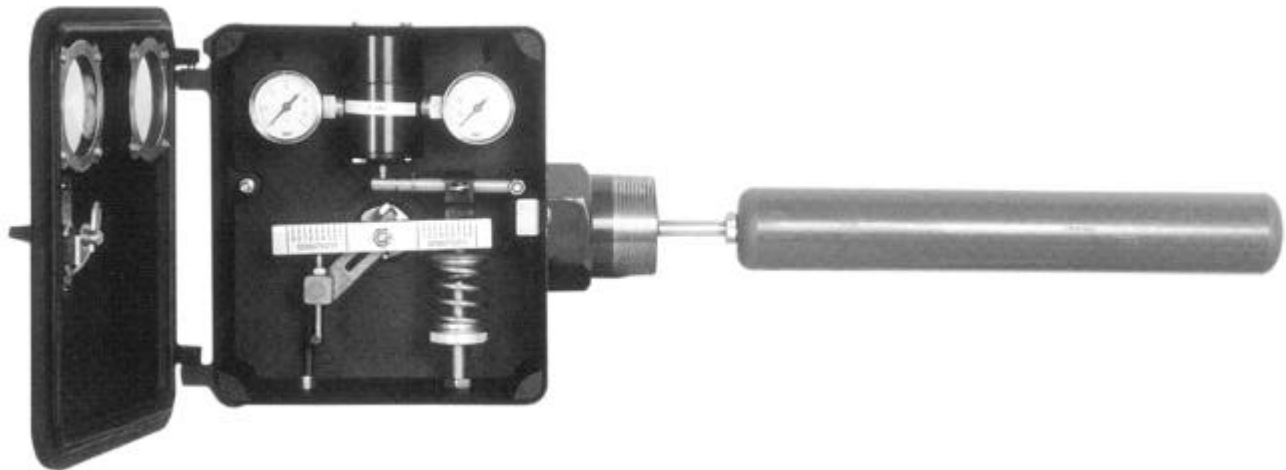

**Specifications:****Available End Connection Sizes**

Threaded:	1.5" or 2"
Butt Weld:	1.5" or 2"
Flanged:	2", 3", 4", 6", or 8"

**End Connection / Pressure Ratings<sup>1</sup>**

MNPT	/	6000 psig (414 bar)
150# RF	/	275 psig (19 bar)
300# RF	/	740 psig (51 bar)
600# RF	/	1480 psig (102 bar)
600# RTJ	/	1480 psig (102 bar)
900# RF	/	2220 psig (152 bar)
900# RTJ	/	2220 psig (152 bar)
1500# RF	/	3750 psig (259 bar)
1500# RTJ	/	3750 psig (259 bar)
2500# RF	/	6170 psig (426 bar)
2500# RTJ	/	6170 psig (426 bar)

**Pilot**

Snap (on/off), 0-20 / 0-30 psig output
Throttle (modulating), 3-15 / 6-30 psig output

**Supply Pressure Requirement**

3-15 or 0-20 psig output:	20-30 psig min.
6-30 or 0-30 psig output:	35-40 psig min.

**Supply & Output Connections**

1/4" fnpt

**Operating Temperature Limits**

See Table 1

**Seal Temperature Ratings**

Buna:	-20 to 180°F (-29 to 82°C)
Viton:	-20 to 400°F (-29 to 204°C)

**Displacer Pressure Ratings**

See Table 2

**Minimum Allowable Fluid Specific Gravity**

See Table 3

**Materials of Construction**

Body:	Steel
Case & Cover:	Die Cast Aluminum
Pilots:	Aluminum with SST Internals
Pilot Gaskets/Diaph.:	Buna Viton (optional)
Gauges:	Bronze 316 SST (optional) 316 SST LF (optional)
Shaft:	303 SST 316 SST (optional)
Bearing Blocks:	303 SST 316 SST (optional)
Bearings:	440C SST
Seals:	Buna Viton
Displacer:	PVC Acrylic (optional) 316 SST (optional)
Displacer Arm:	302 SST
Vertical Hanger (swivel):	316 SST
Vertical Displ. Ext. Chain:	302 SST

1. Maximum pressure ratings @ 100°F (38°C)

Table 1. Operating Temperature Limits

Body Material	Seals	Displacer Material	Temperature Limits	
			°F	°C
C.S.	Buna	PVC	-20 to 140°	-29 to 60°
C.S.	Buna	Acrylic	-20 to 180°	-29 to 82°
C.S.	Buna	316 SST	-20 to 180°	-29 to 82°
C.S.	Viton	PVC	-20 to 140°	-29 to 60°
C.S.	Viton	Acrylic	-20 to 200°	-29 to 93°
C.S.	Viton	316 SST	-20 to 400°	-29 to 204°

Table 2. Displacer Pressure Ratings

Material	Maximum Pressure	
	Psig	Bar
PVC	6170	426
Acrylic	6170	426
316 SST	2000 @ 180°F, 1595 @ 400°F <sup>1</sup>	138 @ 82°C, 110 @ 204°C <sup>1</sup>

- For applications requiring higher pressure ratings for SST displacers, consult Factory or your local Mallard representative.

Table 3. Minimum Allowable Fluid Specific Gravity

Top Level Control			Liquid-Liquid Interface Level Control				
Pilot	Horizontal Displacer	Vertical Displacer	Pilot	Horizontal Displacer		Vertical Displacer	
	Standard <sup>1</sup>	Standard <sup>2</sup>		Std <sup>1</sup>	Special <sup>3</sup>	Std <sup>2</sup>	Special <sup>3</sup>
Snap	0.28	0.21	Snap	0.28	0.030	0.21	0.050
Throttle	0.56	0.42	Throttle	0.56	0.060	0.42	0.100

- Based on 1.88" dia. x 12" displacer with 12.5" displacer arm.
- Based on 1.88" dia. x 12" displacer with 15" displacer arm.
- Special displacer and displacer arm configurations required - consult Factory or your local Mallard representative.

## Theory of Operation

The operation of the Series 3201 Liquid Level Controller is based upon the "Force Balance Principle", illustrated in Figure 1. The weight of a displacer-type level sensing element produces a force which is applied to one side of the Torque Bar through a series of shafts and levers. This force is balanced by the opposing force of a compressed spring on the other side of the Torque Bar. As the level rises, the increased immersion of the displacer in the liquid causes the relative weight of the displacer to decrease, due to the buoyancy force being produced. This, in turn, results in a decrease in force applied to the Torque Bar. The Torque Bar then rotates until the forces are again balanced. Torque Bar rotation is detected by the pilot through a fulcrum mounted on a lever (Flapper Bar) to affect the desired controller output. The output signal can be a pneumatic on/off signal by using the snap pilot, a pneumatic modulating signal by using the throttle pilot.



Figure 1.

## Controller Action

Controller action is determined by the installation of the Flapper Bar, as shown in Figure 2. Control is considered "Direct-Acting" when the controller output changes in the same direction as the liquid level. For example, the controller output signal will increase when the liquid level the controller is sensing increases, and vice versa. Control is considered "Reverse-Acting" when the controller output changes in the opposite direction as the liquid level. For a direct-acting controller, the Flapper Bar pivot point is on the same side as the spring. For a reverse-acting controller, the Flapper Bar pivot point is on the opposite side as the spring.

## Proportional Band

Proportional band is the ratio of used displacer length versus the total length of the displacer to achieve a desired output signal.

**EXAMPLE:** If six inches of liquid level change will develop the required output signal (such as 3-15 psi) and a 12" long vertical displacer is used, then the level controller is said to have a 50% proportional band. Sliding the fulcrum on the flapper bar away from the pivot pin toward the snap ring decreases proportional band (increases sensitivity), while sliding the fulcrum on the flapper bar away from the snap ring toward the pivot pin increases proportional band (decreases sensitivity). A desired output signal (such as 3-15 psi or 6-30 psi) may be accomplished over any portion of the displacer by adjusting the fulcrum as described above.

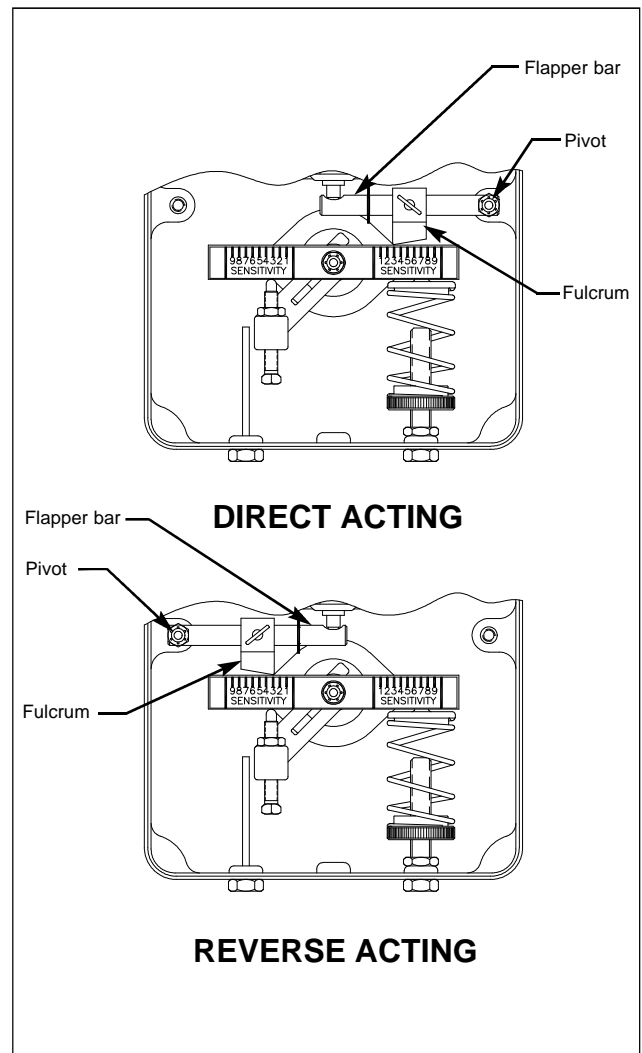

Figure 2. Controller Action

### Snap Pilot Operation

The snap pilot (Figure 3) is made up of two valves: one to admit system supply pressure and one to exhaust system pressure. Ball "X" controls the flow of supply gas into the pilot and is held closed on the pilot seat by force exerted by the supply pressure acting upon the seating area of the ball.

When force transmitted from the flapper bar to the thrust pin "Y" becomes sufficient to overcome the force holding ball "X" seated, ball "X" snaps off the pilot seat allowing supply gas to flow past ball "X" and through the output port of the pilot. The spherical seating end of the thrust pin "Y" seats and closes the exhaust port simultaneously when ball "X" snaps open. The seating area of the thrust pin is smaller than the seating area of ball "X"; therefore, the thrust pin must remain seated against the supply pressure until force on the thrust pin from the flapper bar diminishes.

A simultaneous action occurs as force from the flapper bar on the thrust pin "Y" is removed. When this happens, the supply pressure will unseat the thrust pin and open the exhaust port in the pilot and ball "X" will reseat and close off the supply port. The difference in seating areas gives this pilot its "snap" action.

### Throttle Pilot Operation

The throttle pilot (Figure 4), like the snap pilot, is also made up of two internal valves. In addition, the throttle pilot utilizes a resilient diaphragm "Z" in conjunction with the valves to create a Force Balance Pilot.

The pilot output supply pressure acts upon the diaphragm "Z" so that the diaphragm pushes back with the same force being applied to the thrust pin by the flapper bar, thus the term *Force Balance*.

The throttle pilot functions in a similar manner as the snap pilot except that the output pressure is proportional to the amount of force applied to the lower seat by the flapper bar. An increase in force on the thrust pin produces a proportionate increase in pilot output pressure.

As forces change on the thrust pin, the pilot seeks a new balance point by exhausting the supply output at valve "Y" or unseating valve "X" to increase output pressure. Supply gas does not flow while the pilot is in balance.

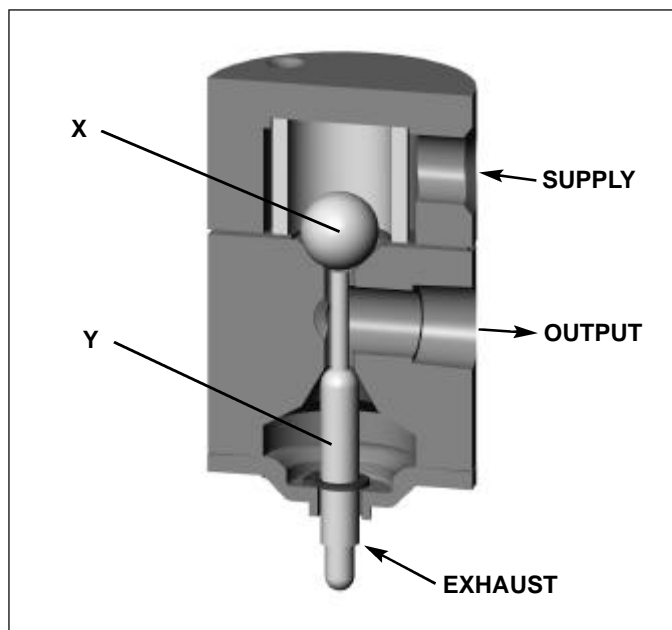

Figure 3. Snap Pilot

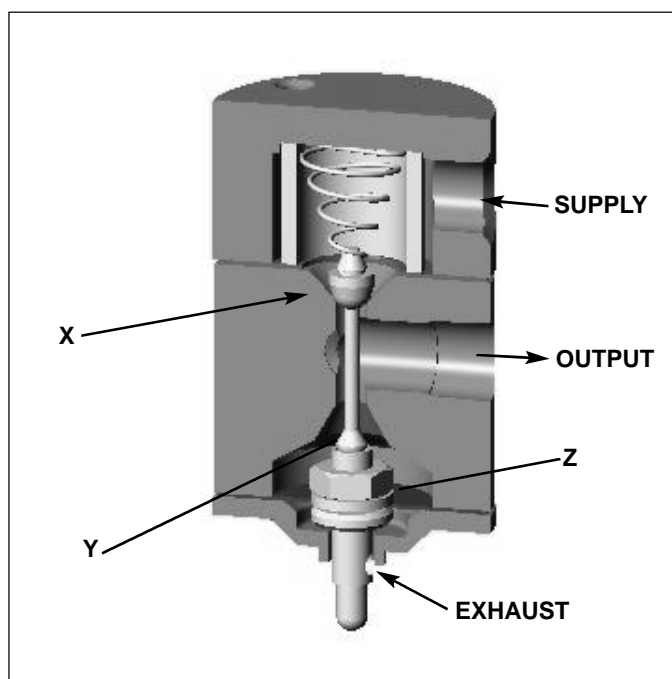
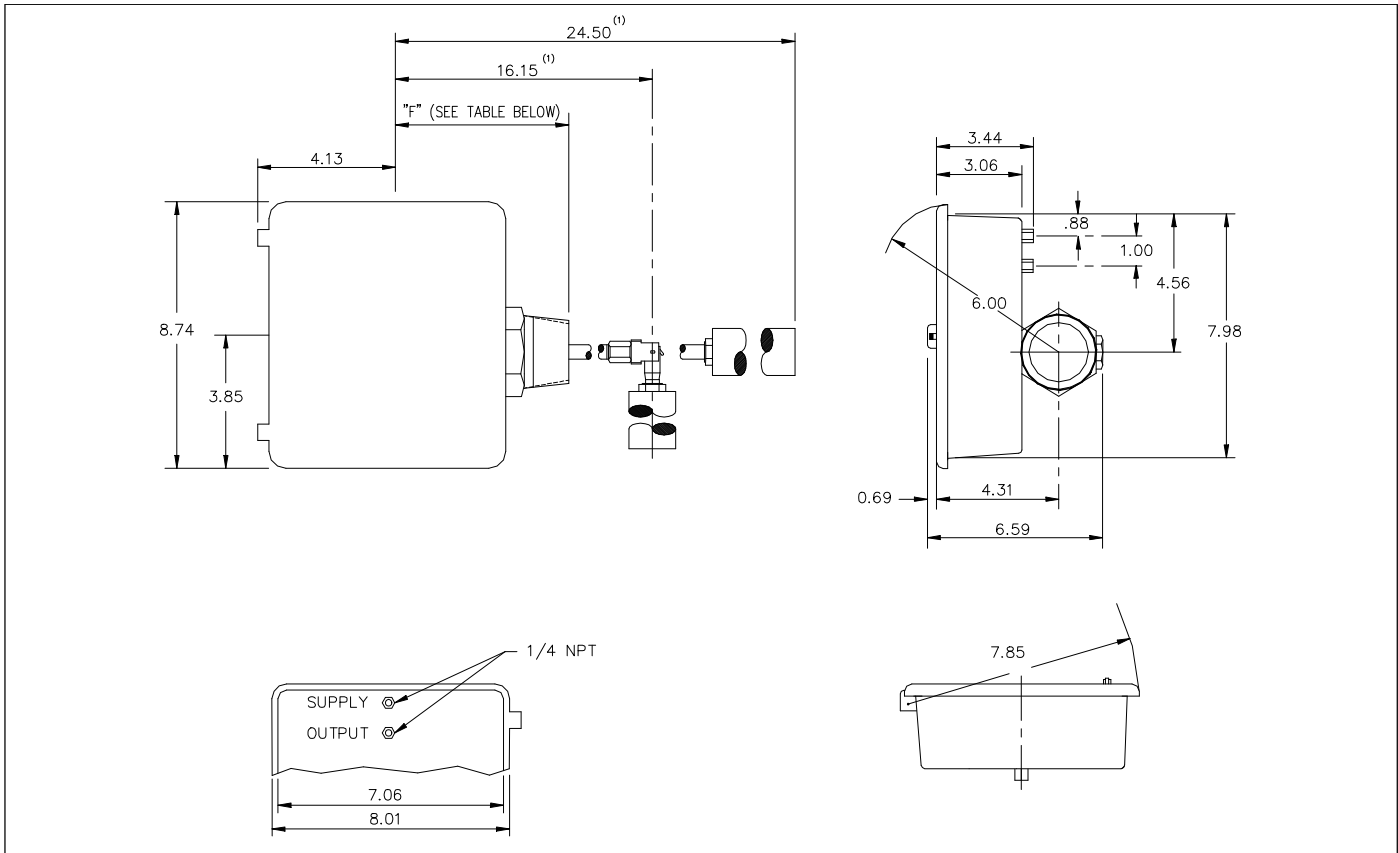

Figure 4. Throttle Pilot

**Dimensions:**



1. 16.15" dimension based upon standard vertical service configuration of 15" arm with a 12" lg. displacer. Other arm lengths and displacer sizes are available upon request. 24.50" dimension based upon standard horizontal service configuration of 12.50" arm with a 12" lg. displacer. Other arm lengths and displacer sizes are available upon request.

Vessel Connection	Dimension "F"				
	Body Size				
	2.00	3.00	4.00	6.00	8.00
Butt-Weld Sch. 40	6.00	-	-	-	-
Sch. 80	6.00	-	-	-	-
Sch. 160	6.00	-	-	-	-
Sch. XXH	6.00	-	-	-	-
Slip-on	6.00	-	-	-	-
Screwed Male NPT	6.00	-	-	-	-
Grooved	6.00	6.88	6.94	6.04	*
150# RF	6.50	6.56	6.56	6.50	*
300# RF	6.81	6.75	6.88	6.94	*
600# RF	7.19	7.12	7.50	11.0	*
600# RTJ	7.25	7.31	7.56	11.0	*
900# RF	8.00	9.63	10.13	*	*
900# RTJ	8.06	9.69	10.19	*	*
1500# RF	8.00	10.25	10.63	*	*
1500# RTJ	8.06	10.31	10.69	*	*
2500# RF	8.50	11.06	11.75	*	*
2500# RTJ	8.56	11.13	11.81	*	*

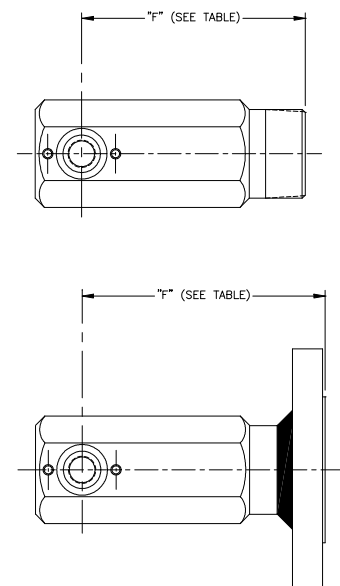

\* Consult Factory

### Information Required for Proper Selection of the 3201 Liquid Level Controller:

1. Fluid Media
2. Fluid Temperature: Maximum & Minimum
3. Operating & Design Pressure
4. Body Connection Size & Type
5. Displacer Orientation: Horizontal or Vertical
6. Displacer Arm Length: Arm length is figured from the centerline of the controller case to where the displacer attaches to the arm. Standard arm lengths are 12.5" for Horizontal displacers and 15" for Vertical Displacers. Other arm lengths are available upon request.
7. Determine mounting orientation (See Figure 5).

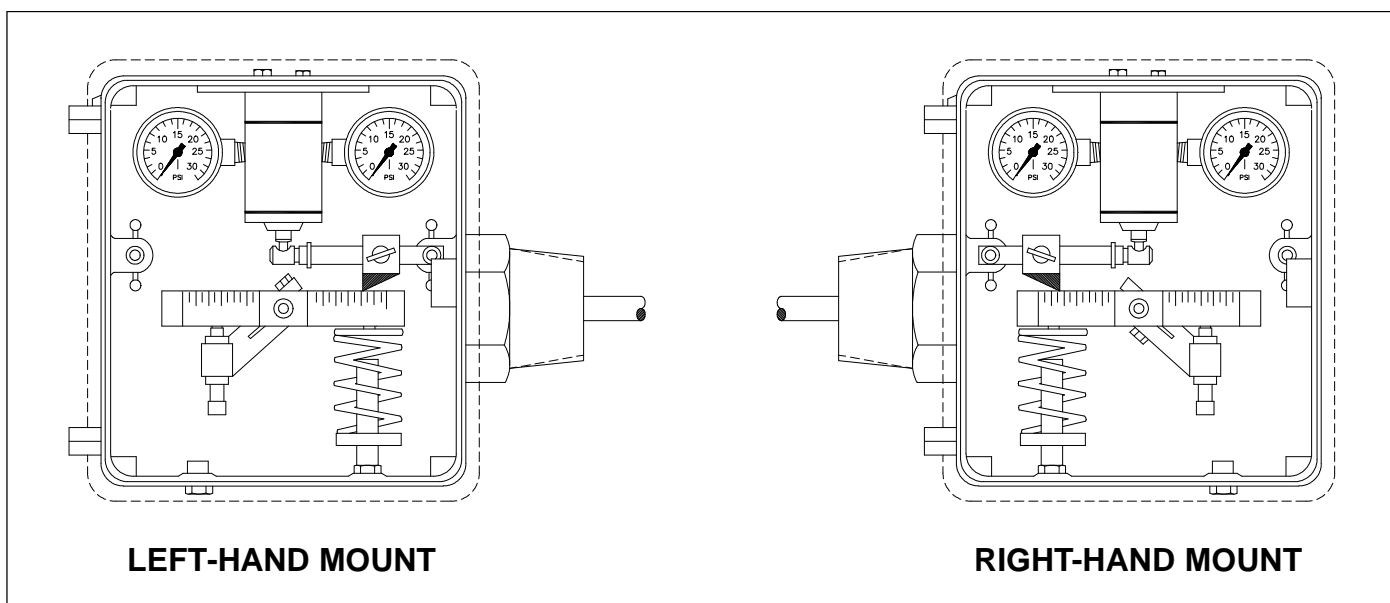

Figure 5. Controller Mounting

### Mounting

The Series 3201 Liquid Level Controller can be set up as right-hand mount or left-hand mount. The orientation of the level controller mounted to the vessel, while facing the front of the controller, determines the mounting style (Figure 5). If the controller is to be mounted on the right side of the

vessel, then it is considered "right-hand". If the controller is to be mounted on the left side of the vessel, then it is considered "left-hand". The mounting orientation can be easily reversed in the field.

## Model Number Information

Sample Model Number: 3201 - 20 MS 0 - S RD B - S A

END CONNECTION		CODE
1.5"		15
2"		20
3"		30
4"		40
6"		60
8"		80

END CONNECTION TYPE		CODE
Screwed MNPT		MS
Butt-Weld, Sch. 80		B8
Butt-Weld, Sch 160		B1
Raised Face Flange		RF
Ring Type Joint Flange		RJ
Special - to be specified		SP

PRESSURE RATING		CODE
MNPT (6000 psig)		0
ANSI 150 ( 275 psig)		1
ANSI 300 ( 740 psig)		3
ANSI 600 (1480 psig)		6
ANSI 900 (2220 psig)		9
ANSI 1500 (3750 psig)		5
ANSI 2500 (6170 psig)		2

MATERIALS OF CONSTRUCTION			CODE
Body	Shaft	Brg. Block	
1018 / A105 C.S.	303 SST	303 SST	-
1018 / A105 C.S.	316 SST	316 SST	A
1018 / A105 C.S. (NACE)	316 SST	316 SST	N

PILOT		CODE
Snap (Pneumatic on/off)		S
Throttle (Pneumatic Modulating)		T

MOUNTING / CONTROLLER ACTION		CODE
Left Hand / Direct		LD
Left Hand / Reverse		LR
Right Hand / Direct		RD
Right Hand / Reverse		RR

SEAL MATERIAL		CODE
Buna		B
Viton		V
Special - to be specified		X

GAUGE TYPE		CODE
0-30 psi, Brass Internals		S
0-60 psi, Brass Internals		T
0-30 psi, 316 SST Internals		3
0-60 psi, 316 SST Internals		6
0-30 psi, Brass Internals, Liquid-Filled		A
0-60 psi, Brass Internals, Liquid-Filled		B
0-30 psi, 316 SST Internals, Liquid-Filled		C
0-60 psi, 316 SST Internals, Liquid-Filled		D

CONTROLLER CASE		CODE
Standard		A

While this information is presented in good faith and believed to be accurate, Mallard Control Company does not guarantee results based upon such information. Mallard Control Company reserves the right to change the design or specifications of these products without notice.

### Mallard Control Company, Inc.

4970 Washington Boulevard  
 Beaumont, Texas, USA 77707  
 409 842-5392 Phone  
 409 842-8165 FAX  
 www.MallardControl.com

Distribuidor en México

LAVISIA, S.A. de C.V.  
 Teléfonos 55.1106.0000 Fax 55.5000.3623  
 Correo electrónico ventas: ventas@lavisa.net  
 Página Web: www.lavisa.net